



*MEDIUS  
TERRA  
COLLEC-  
TION  
2024*

URB|  
+  
ORB|



# INNOVATION LINKED WITH CONCRETE



3

We live in a fast-paced world, where infinite images succeed one another at a rapid pace and in the end, we do not have time to see the depth in any of them until they eventually become two-dimensional.

At URBI et ORBI, we love to give duration to the moments. We enjoy the present before it becomes the past. We refuse to look only at the surface; we seek the underlying meanings, emotions and messages.

At URBI et ORBI, we insist on believing in timeless values. A product can be more than just an object. It can have a long-term existence, and age gracefully without deteriorating. It can be the space, not merely fill it. In addition to its functionality, a product should have character, spirit, and personality. It should awaken memories and emotions, engage in a dialogue with the user, have an identity, move through space and time, create relationships and experiences. We want to receive and transmit messages. We produce and propose products that have life.

Established in Athens in 2012, URBI et ORBI has spent a decade showcasing the versatility of concrete as a premier material for design products. Collaborating with esteemed designers, we have curated exceptional collections across bathroom and living spaces. Throughout our journey, we have earned recognition and acclaim from professionals worldwide, 'cementing' our reputation as innovators in the industry. With an innovative viewpoint, we evolve, experimenting with new techniques and finishes, regarding each new design as a challenge.

Central to our production process is concrete, our primary raw material. Infused with technologically advanced components and complemented by secondary materials like wood and metal, our products embody a blend of form and function. Handcrafted with meticulous attention to detail, our creations adhere to European standards and directives, ensuring quality and reliability.

Concrete is considered by many a mass that is not eco-friendly because it is artificial, but cement is just a minuscule fraction of the overall composition. Over time, concrete integrates seamlessly into the environment, aligning with nature's rhythms. At URBI et ORBI, we believe in effortless effort, balance, coexistence, and harmony. We listen to the genius of nature and strive to emulate it.

Concrete can be recycled, and we make it a natural part of our process to do so because we want our ecological footprint to be nominal. We use raw materials that we find near Athens, reusing the sand collected from processing in the workshop. We have chosen to recycle 100% of our waste internally in our production.

We create harmony.

# UNVEILING THE MEDIUS TERRA

Urbi et Orbi presents the Medius Terra collection, a captivating celebration of the Mediterranean's soul. More than just a collection, it embodies our essence – a testament to the enduring character of this remarkable region.

Inspired by the Genius Loci, the spirit of the place, Medius Terra delves into the heart of the Mediterranean. It's an ode to the sun-drenched landscapes, the vibrant cultures, and the timeless traditions that weave the fabric of this cherished sea and its surrounding lands.

The distinctiveness of this collection arises from the fusion of diverse perspectives brought forth by the three contributing designers: Gian Paolo Venier OTTO Studio, sotirislazoudesignstudio, and CTRLZAK.

Three distinct chapters – Gea, Zoe, and Forma – which come together in harmonious conversation to encapsulate the Medius Terra collection.

Gea represents the very essence of the Mediterranean. It's a ride designed to awaken the senses and build connections with the beauty that surrounds us, capturing the essence of the soil, the landscape, the flora, and the fauna in a sensory experience.

Zoe delves into the human spirit that thrives in this region. It's a celebration of everything that we are, our existence, our vitality, our culture, our way of life. Even for those who haven't experienced it firsthand, the collection evokes a profound connection, a feeling of truly being there.

Forma focuses on the aesthetics that define the Mediterranean. It's a study of the forms, the shapes, the cohesiveness, the architecture, a silent storyteller whispering tales of the region's architectural heritage.

The uniqueness of Medius Terra lies in the beautiful synergy between these diverse perspectives. As shapes communicate, hues characterize, and touch is sensed, emotions, aromas, and flavors of the Mediterranean, spring to mind, creating a collection that transcends the visual, transporting you to the heart of this captivating region.

Medius Terra is a testament to the enduring power of nature and human craftsmanship. It's a collection shaped by the elements, meticulously handcrafted with a focus on detail, a hallmark of Urbi et Orbi.

# A SYMPHONY OF THE MEDI- TERRANEAN

4

5

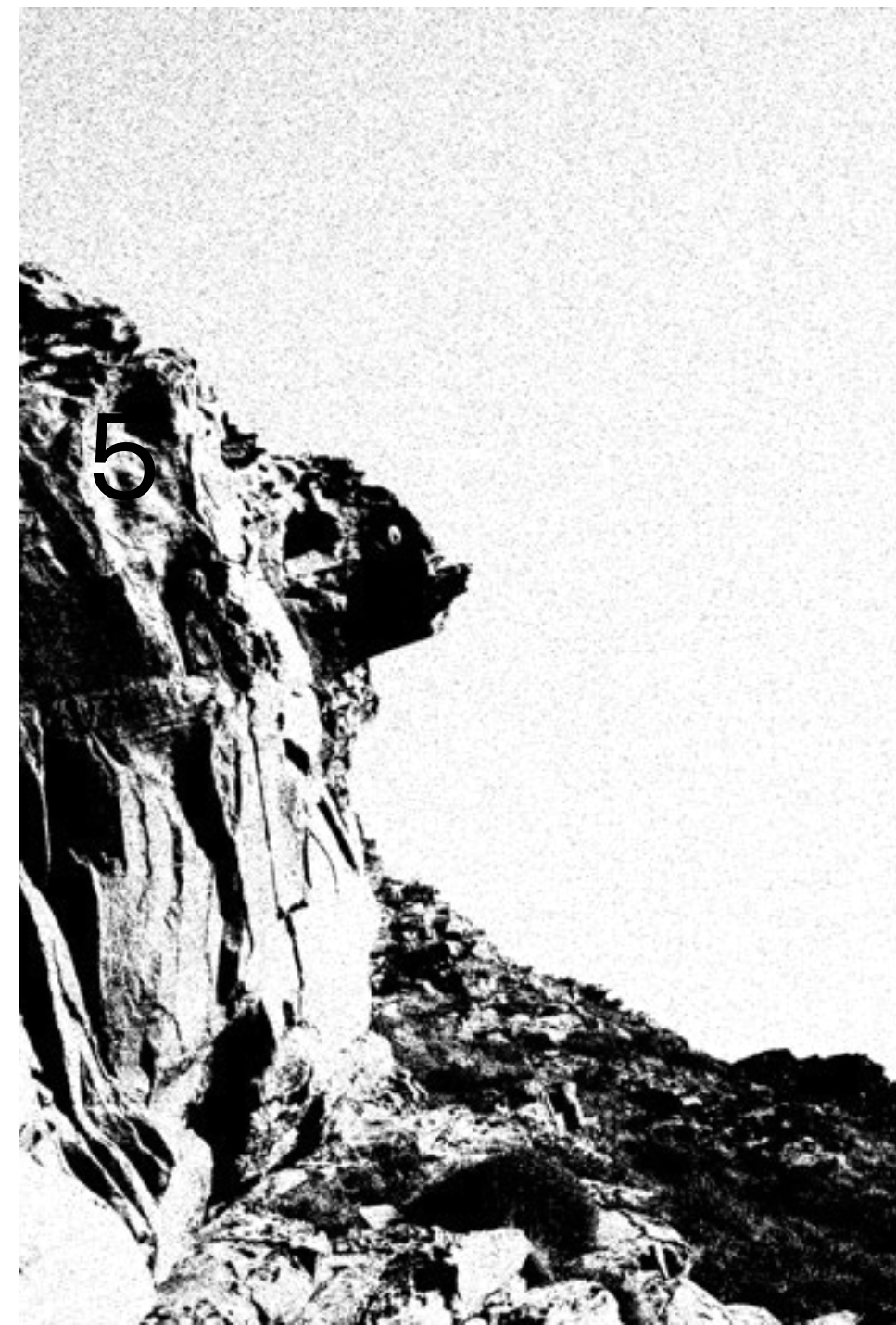

# GEA

6

# EARTH, HOW DID IT ALL BEGIN?

7



GEA embraces the earthy hues and the organic textures of the landscape, paying homage to the land itself. In this collection, the Mediterranean land is the muse, inviting both the designers and the users to immerse themselves in its captivating allure. From rugged coastlines to sun-drenched olive groves, each piece in this collection exudes a sense of grounding and connection to nature. All these countries under the canopy of this glorious Mediterranean region are linked by ancient trade routes and various civilizations, erasing the ephemeral and embracing enduring legacies. Highlighting the unique and earthy palette of the area, terracotta has a robust presence, while each object is a testimony of passing time.



# STRATA

The STRATA series – Design by CTRLZAK  
for Urbi et Orbi.

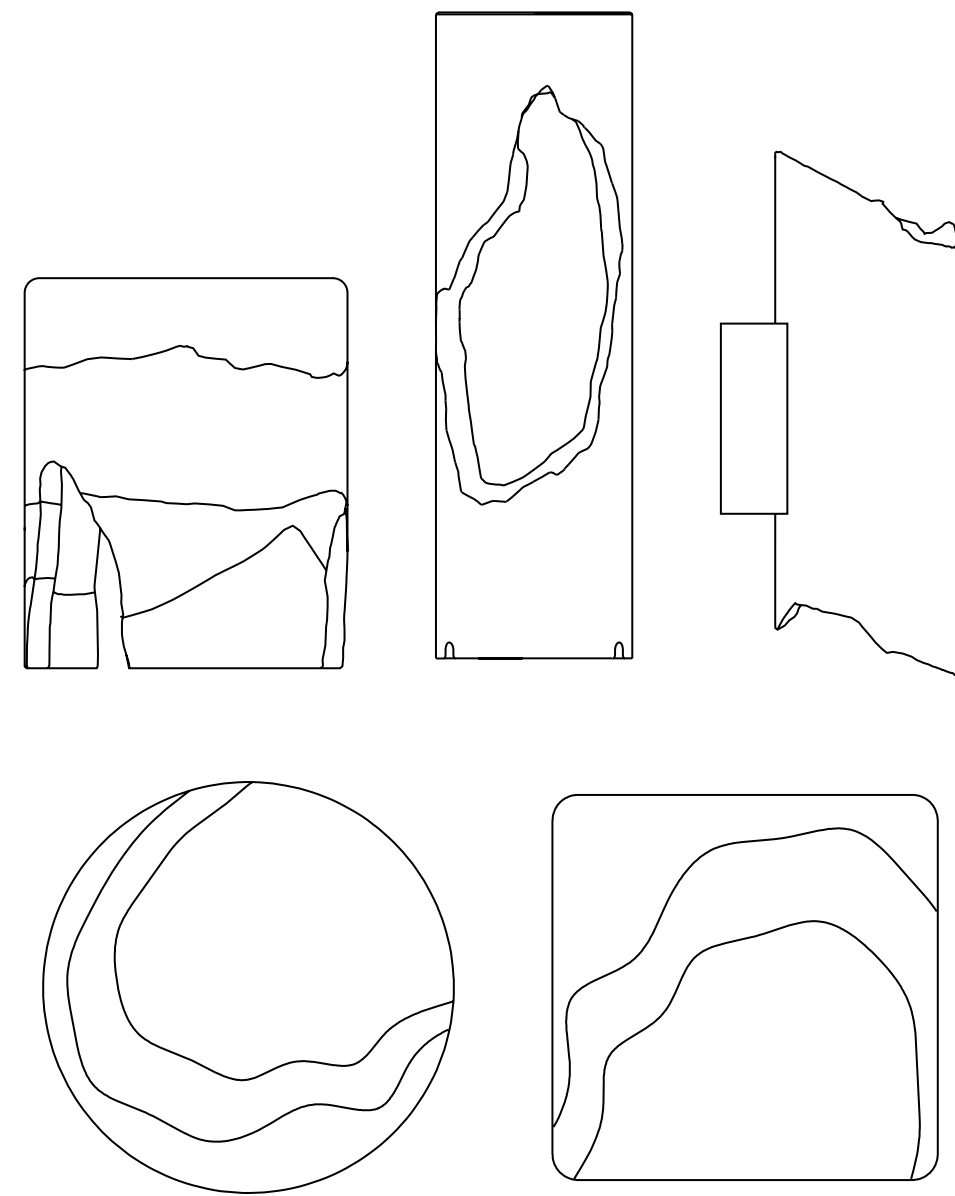

8 9



Stratification is the overlapping of various mineral compositions, where the upper layers are younger than the ones under them, showing the passing of time in stacks of diverse deposits. The Mediterranean basin is home to a multitude of diverse geological phenomena, with a rich story of sedimentation, erosion, and strong volcanic activity, all of which contribute to make a unique stratified environment. This concept makes us reflect on our conception of time through the geological spectrum in the Mediterranean and our planet as a whole.





10 11





12





# TUS

The TUS series – Design by Gian Paolo Venier OTTO Studio  
for Urbi et Orbi.

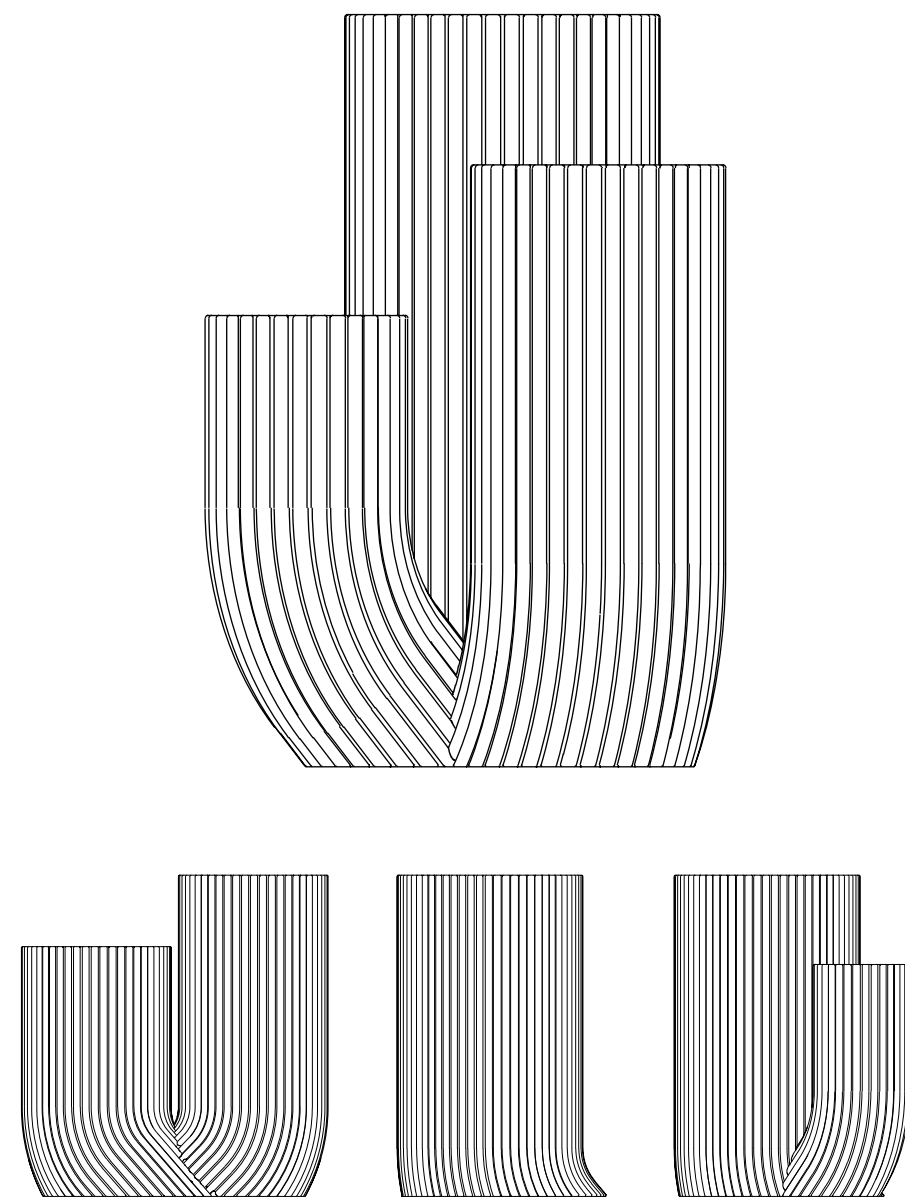

14 15



TUS is a series of four side tables/stools and talks about earth, about the vegetal feeling and organic forms. This project investigates nature's mathematical precision in producing seemingly organic and imprecise forms, and is fascinated by pattern repetition. The shape resembles that of a cactus, a cactus garden. A quote from man's intervention on nature (*Le Jardin Majorelle* - Marrakesh), the use of nature in architecture, always a fascinating gesture.







# ZOE

18

19

## WHAT IS THE TRUE ESSENCE OF LIFE?



Inspired by the vibrant vitality of Mediterranean life, ZOE embodies the spirit of joy, warmth, and 'filoxenia' (hospitality). From bustling marketplaces to tranquil seaside villages, this collection captures the essence of Mediterranean culture, inviting you to immerse yourself in its rich tapestry of colors, textures, and flavors.



# JAR

The JAR series – Design by Gian Paolo Venier OTTO Studio  
for Urbi et Orbi.

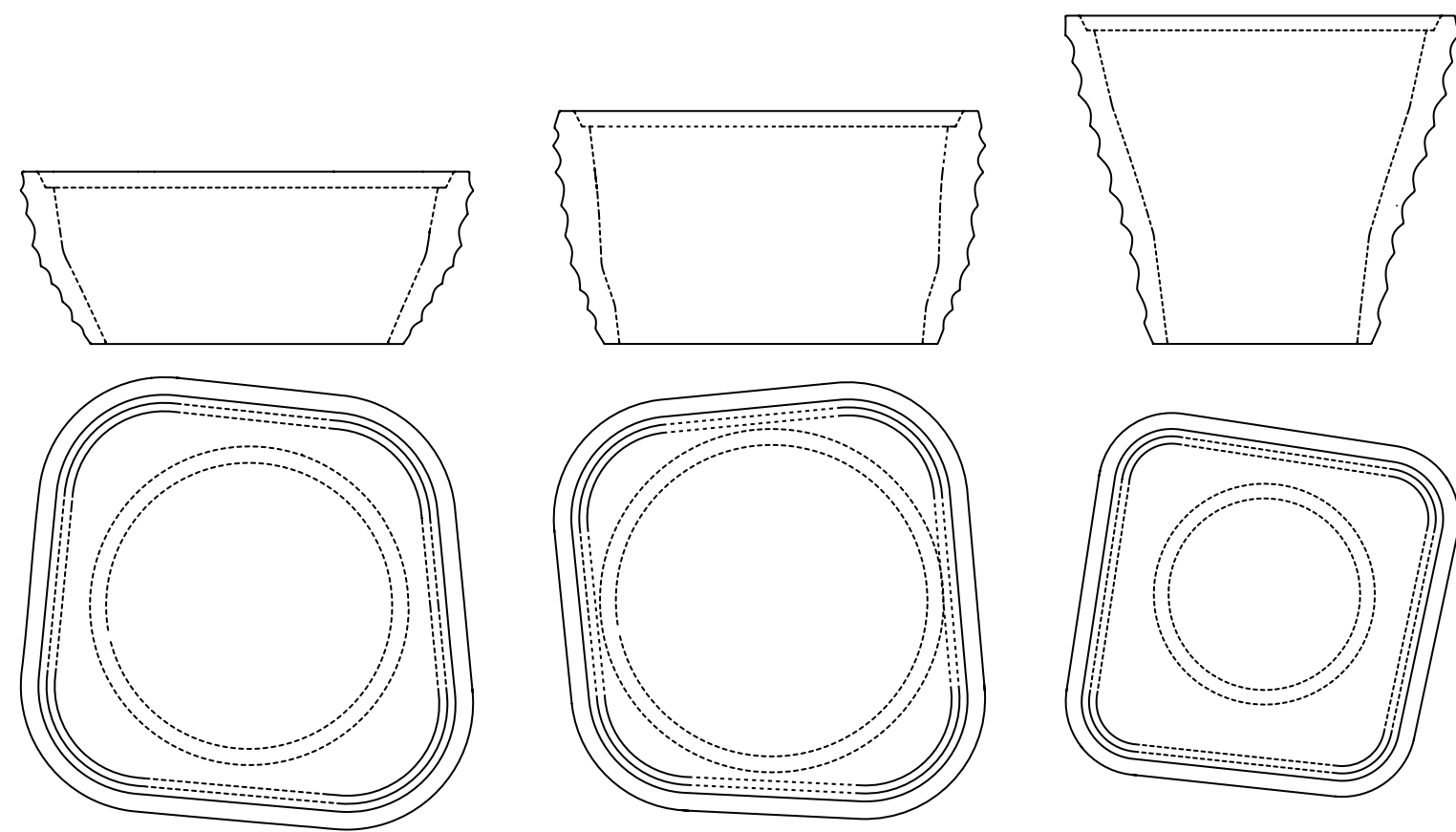

20

21



JAR is a series of three coffee tables and talks about the hands of the craftsman, the intelligent hands (*The Craftsman* - Richard Sennett). It speaks of the imprecision of manual work by observing its beauty. The ratios of the measurements of these three tables are deliberately forced to give them a soft shape, which tells of the earth. In this case, cement is treated like clay, a material that aspires to be natural and therefore precious.



# VIKA

The VIKA pendant lamp – Design by sotirislazoudesignstudio for Urbi et Orbi.

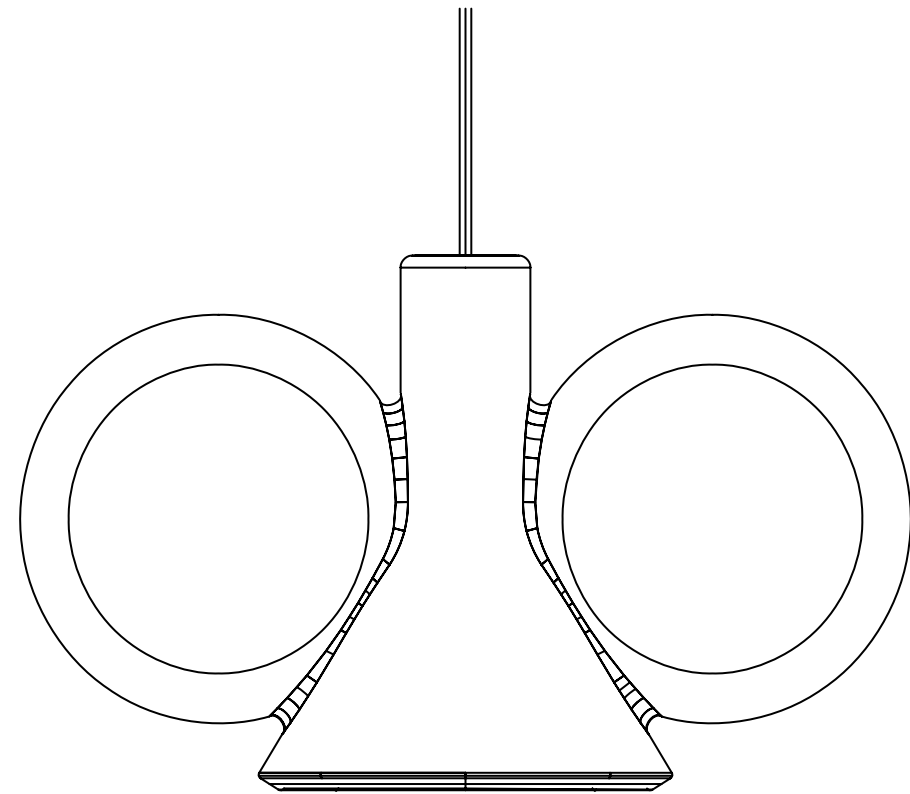

22

23

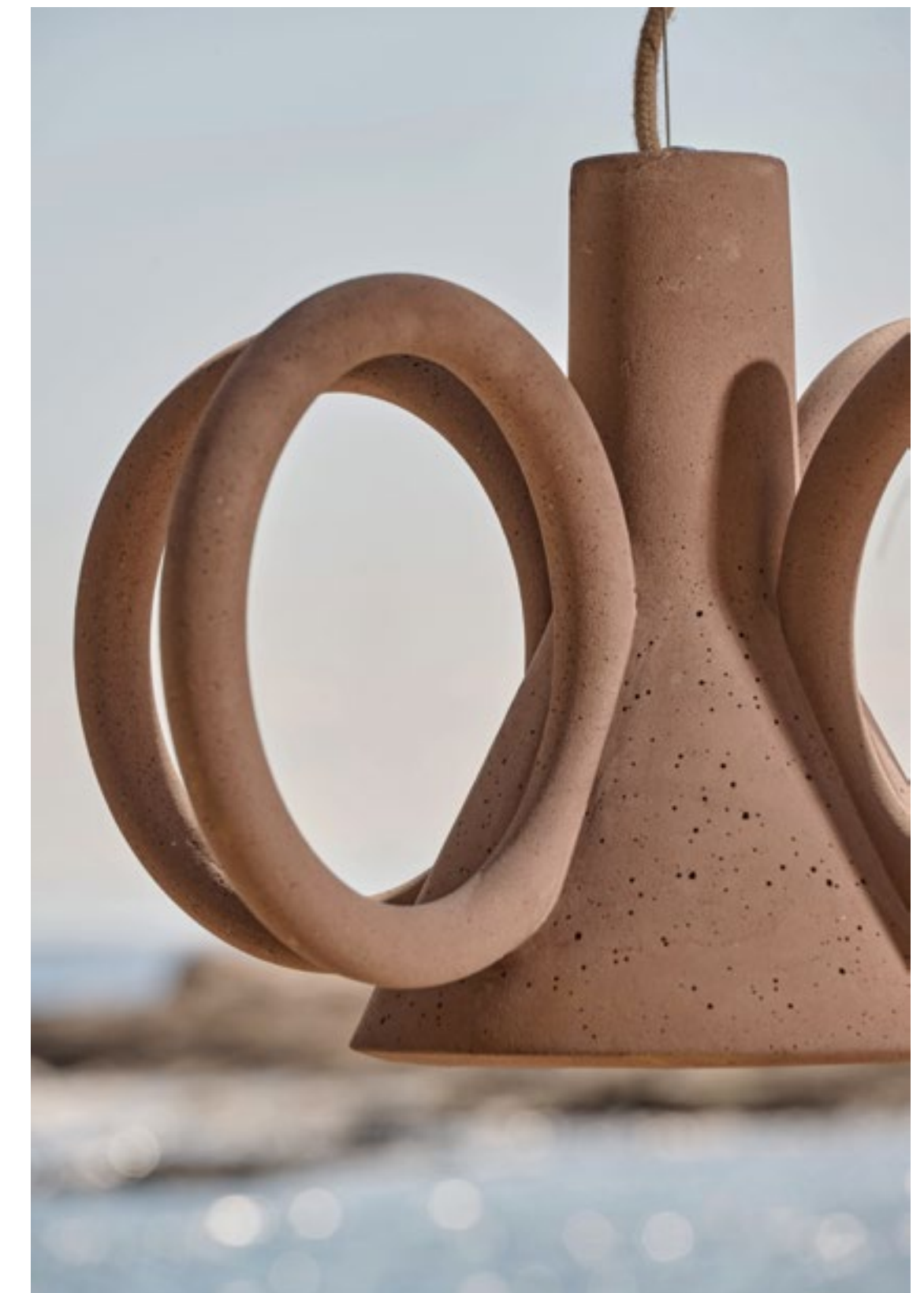

As a component of ZOE, VIKA illuminates the lifestyle of ancient Greece. The βίκοϋ (small jar) once served as a vessel for transporting water, and now it serves as the muse for this pendant lamp, wrapped in earthy colors like those of ancient vika. Following its inspiration from Greek pottery, VIKA embodies the enduring grace and sophistication, emblematic of this region. The perpetual flow of water is identified with the eternal source of light, while these cylindrical hangers, arranged around the body of the lamp, evoke a compelling urge to reach out and experience the design's rich history firsthand. The selection of materials further accentuates VIKA's ties to its Mediterranean heritage, with earthy terracotta hues and organic textures paying homage to the rustic charm of the area. Balancing modernity with tradition, VIKA masterfully melds into contemporary environments while imparting a distinct Mediterranean flair.



Μην με δέρνεις καλέ μάνα  
που 'σπασα καινούργια στάμνα  
κι η βαρέλα ας είν' καλά  
και θα πιούνε τα παιδιά

Με πειράξανε στο δρόμο  
πάει η στάμνα από τον ώμο  
κι η βαρέλα ήταν βαριά  
μου την ρίξαν τα παιδιά

Κι όλοι με πειράζουν μάνα  
και μου λένε πάει η στάμνα  
δεν αντέχω πια η δόλια  
για να ακούω τέτοια λόγια

Πες μου τώρα τι να κάνω  
και στη βρύση που θα πάω  
δίχως στάμνα και βαρέλα  
μάνα μου θα μου 'ρθει τρέλα

24





# SAROMA

The SAROMA side table – Design by sotirislazoudesignstudio  
for Urbi et Orbi.

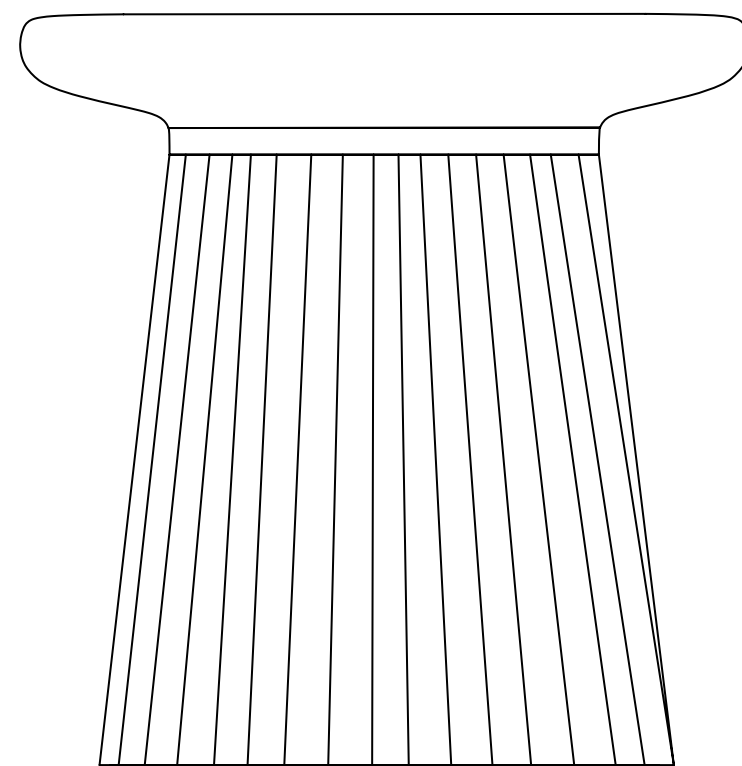

26

27

SAROMA stands out as a testament of living. A move of sweeping (σάρωμα) was behind the inspiration of this product. As part of ZOE, this table celebrates the Mediterranean natural style while connecting memories and evoking a sense of warmth and authenticity. By incorporating raw materials from natural straw brooms, a unique and organic touch was added to the table design. A small table with a concrete top and metal base, inspired by traditional Mediterranean craftsmanship and architecture, creates a harmonious blend of functionality and aesthetics. The use of concrete for the tabletop represents durability and practicality, while the metal base adds a touch of industrial elegance. Through the exploration of natural forms, the incorporation of raw material from natural straw brooms adds a distinct texture and visual interest to the table, evoking a sense of nostalgia and familiarity. By combining traditional materials and contemporary design, SAROMA side table not only serves as a practical piece of furniture but also becomes a representation of cultural heritage and the beauty of sustainable design.





FOR  
MA

28

29

WHY IS  
IT MORE  
THAN JUST  
SHAPE?



Drawing inspiration from the timeless architecture of the Mediterranean region, FORMA celebrates the beauty of geometric forms and structural integrity. With clean lines, elegant curves, and meticulous attention to detail, each design reflects the enduring influence of ancient civilizations on contemporary aesthetics. All this perspective blends remarkably with concrete; one of the noble materials of contemporary architecture. Much like concrete, these objects undergo transformation, evolving over time and adapting to different environments and contexts. Inspired from the past, each approach revives the aspect of design, combining different forms and architectural gestures.



# KAMARA

The KAMARA flower stand and side table – Design by sotirislazoudesignstudio for Urbi et Orbi.

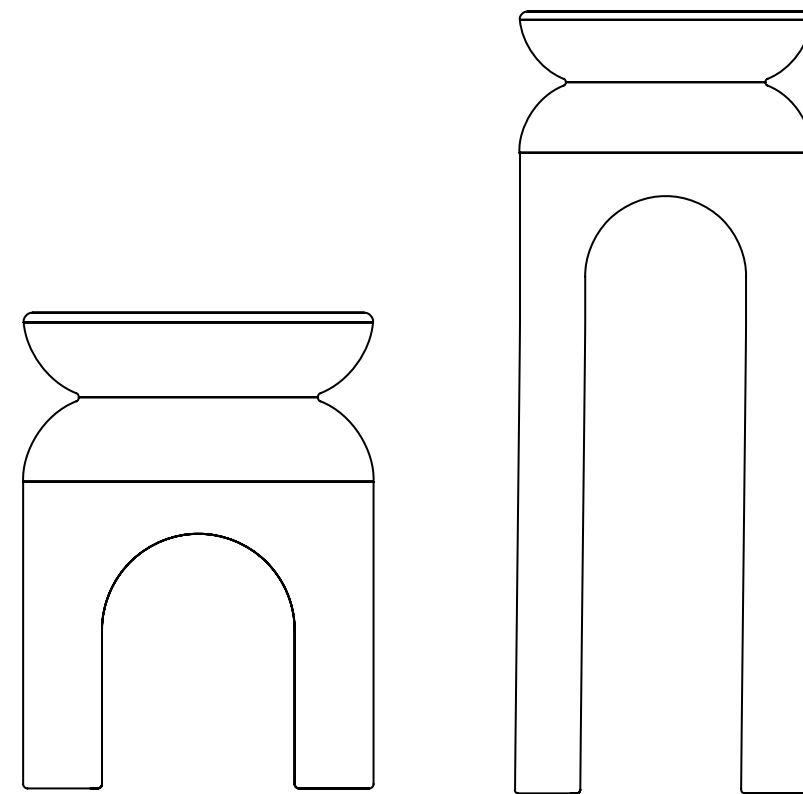

30

31



The iconic arches, prevalent among architectural practices worldwide, particularly in the Mediterranean, serve as inspiration for the designs. Drawing from the Camares of Santorini and Cycladic islands, these FORMA pieces encapsulate the historical and geographical essence of these places, complemented by their vibrant colors. Envisioned with a color palette reflecting the Mediterranean region, these pieces combine white, earth tones, and blue, evoking the serene island atmosphere and vibrant culture. With elements of bohemian luxury, our design achieves a harmonious blend of elegance and comfort. As a piece with its own identity, KAMARA can beautifully blend within a space as a memory of whitewashed buildings with the twist of earthy hues covering the design, echoing the rugged terrain and volcanic landscapes of Santorini.



# LEGANTE

The LEGANTE table series – Design by CTRLZAK  
for Urbi et Orbi.

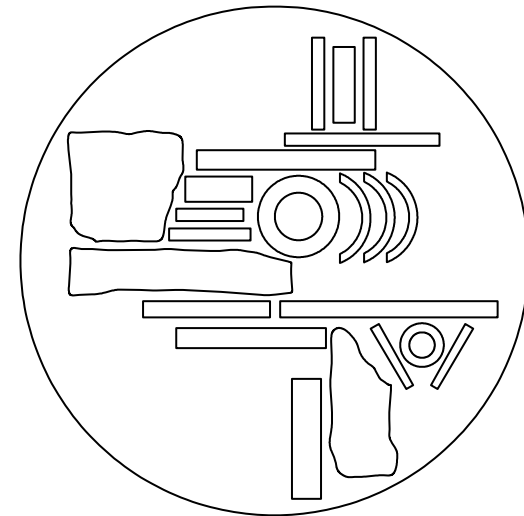
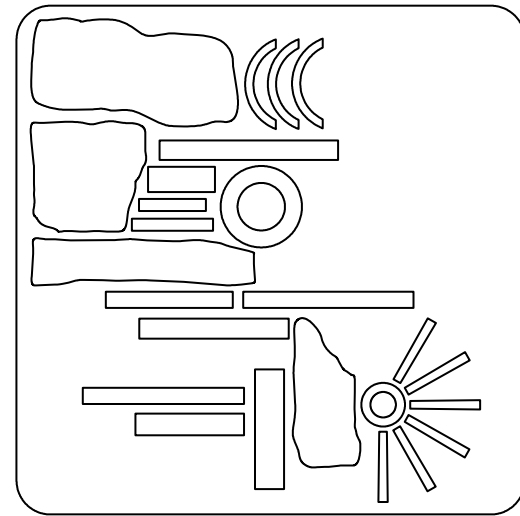
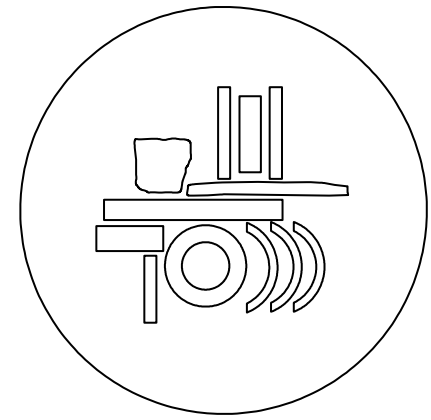

32

33



The Romans used to call it Mare Nostrum, even though it was home to anyone that lived on its coastlines. People, sailing across the Mediterranean, exchanging goods and knowledge (peacefully or not), have left traces of their passing, lifestyles and constructions, building cities with local stones, terracotta bricks and tiles. These traditional elements, combined with modern techniques, create a contemporary terrazzo that reflects on the unique cultural mosaic that is the Mediterranean basin.





### Gian Paolo Venier from OTTO Studio

An inveterate traveller, Gian Paolo travels with agility and a keen interest from east to west, north to south, guided by his instinct to discover new areas of inspiration for his work. He designs interiors, temporary exhibitions, objects and textiles, and also handles creative direction. He loves designing fashion, including his own clothes. And he paints. Born in Trieste, not surprisingly overlooking the Molo Audace, he has lived in London and New York, before moving to Milan. He defines himself as an urban animal, despite having chosen Syros, in the Cyclades, as his place of choice. For now.

Gian Paolo Venier, Cristina Pettenuzzo and Domenico Diego develop interior, product design and art direction projects with Paola Navone for OTTO Studio. This collaboration is always a source of new stimuli and allows you to explore new areas of work.

Born from the creative vision of architect and designer Paola Navone, OTTO is a multi-disciplinary design studio formed by a team of fifteen, which collaborates with a wide portfolio of international clients through a range of projects from interior design to furniture and accessory design, including graphics, styling and creative direction.

The team is dedicated to interior design projects and the development of product and graphic design projects, feeding a continuous creative contamination, which is key to achieving the global vision of the studio; from the scale of architecture to that of the product design scale, down to the detail of style and decoration.



### sotirlazoudesignstudio

Sotirlazoudesignstudio is based in Athens and was founded by Sotiris Lazou in 1995. It specializes in industrial design and also in interior architecture. Sotiris Lazou studied at the University of Western Attica, earning a BA in interior architecture. He completed his Master's Degree in Industrial Design at Domus Academy MA, learning under sacred design monsters such as Andrea Branzi, Alessandro Mendini, Antonio Citterio etc. Sotiris treats all projects with a holistic approach, relying on archetypal forms, aspiring to be timeless.

With each project, his inspiration comes from different stemming ideas. He states that his work is not only a way of life and expression, but also an integral part of his life. He earned a Good Design Award in 2008 for the 'Cosmos', a table produced by Varangis, now located at the Athenaeum Museum of Chicago. The 'Cosmos' was also a nominee for the German Design Awards. He designed an innovative table, produced by al2, the 'Vintme 2', which, in 2014, was a nominee for yet another German Design Award. He again earned a Big See award in 2018 for the 'Woogy' doghouse.

His motto is 'Let's do the Greek design internationally'. He has designed more than 350 items (mainly furniture) for Greek export companies, the majority created for al2 (more than 120 pieces of furniture), that were exported to over 30 countries worldwide. He has participated in major international exhibitions, such as Salone del Mobile, IMM Cologne, 100% Design, and The Hotel Show Dubai. He has taught for almost 20 years at AKTO College and the University of Western Attica. His works and interviews have been published in many Greek and foreign journals.



### CTRLZAK

CTRLZAK is a hybrid studio that integrates diverse disciplines and forms of expressions. Founded by artists and designers Katia Meneghini and Thanos Zakopoulos, the studio's creations are based on extensive research into humanity's cultural history and the natural world that surrounds us in order to create a meaningful future.

Due to its interdisciplinary approach, CTRLZAK specializes in art direction while creating artworks, objects and spaces but above all points of reflection, where form follows meaning. Through the use of semiotic tools within the creative process, the studio conceives projects and orchestrates situations that surpass common aesthetic values, operating on a deeper cognitive level, aspiring to make people consider their actions and the planet that we live in. CTRLZAK has been extensively covered by the international printed and digital press, while their creations have been exhibited in galleries, museums and institutions all over the globe, such as the Venice Art Biennale, the Triennale in Milan, the CID-Grand Hornu, the London Design Biennial and the MAXXI to name a few.





SHAPED  
BY NATURE  
AND BARE  
HANDS

[urbietorbi.gr](http://urbietorbi.gr)